

DX ignition

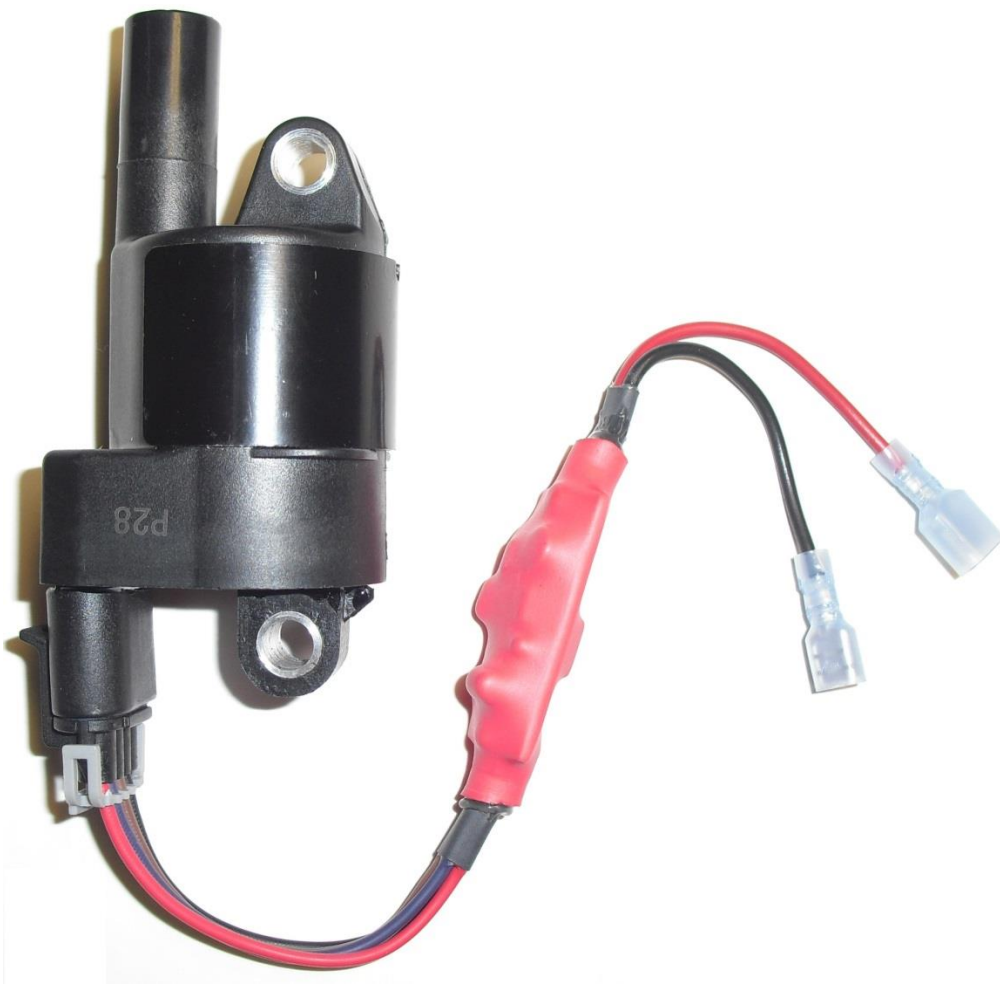

DX Express

1.0 Installation

DX express is designed to be an electronic replacement for Pontiac & Ford buzz coils when operated on 12v. Simply connect the RED wire to 12v and the BLACK wire to the Timer.

Installation Wiring

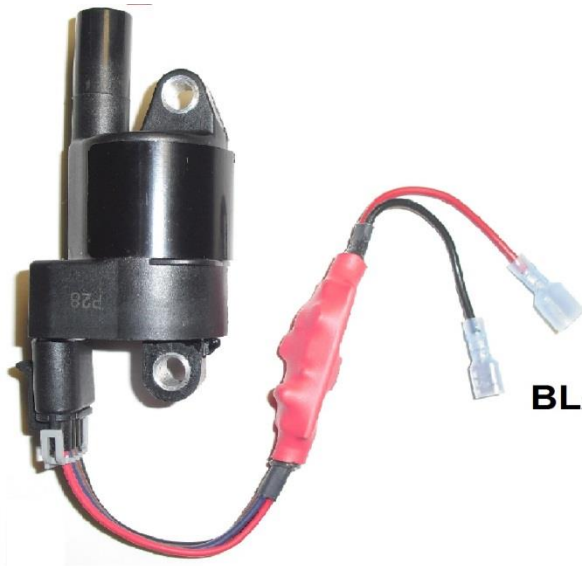

RED wire to 12v ignition switch

BLACK wire to timer points

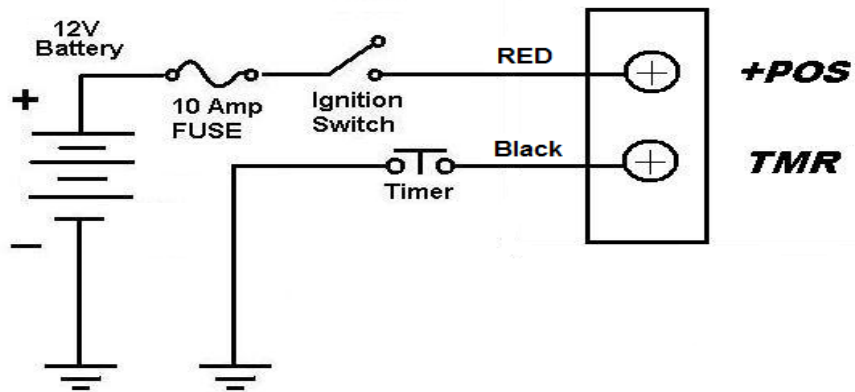

When wiring the input connections use at least 16ga stranded wire, 10 amp fuse, and ignition switch. It is a negative ground system so grounding is very important. It is recommended to make sure the engine and battery have good chassis ground connections.

⚠ It is recommended to test and inspect timer points for proper electrical ground connection to engine.

The timer condenser is not required for the operation of DX ignition and it may be removed. If the condenser is good, you may choose to leave it connected allowing an easy switch between DX ignition and original buzz coil.

For the best performance clean and gap timer points. Follow the procedure defined by Fairmont to adjust the timer points interval to 1/12 of an engine revolution which is the equivalent of 30°. The timer interval determines the number of crankshaft rotation degrees the buzz coil will fire. Significantly less than 30° may cause high RPM stalling, spark plug fouling and slow timer lever response. Greater than 30° effectively advances the ignition timing with relationship to timer lever position.

The red LED on the electronic buzz coil will indicate when the points are closed.

The spark plug wire *must* be resistive or suppression wire. Due to the DX ignition high output copper or steel core plug wire should not be used because it may act as an antenna causing RFI and unwanted noise.

The recommended spark plug gap is 0.045". Resistor or non-resistor spark plugs may be used; however non resistor plugs may contribute noise to other electronic devices.

2.0 Specifications

Operating Temperature	0°F-120°F typical (all components exceed 220°F)
Input Voltage	10.5-15.5v Negative Ground
On Current	<1.5amp average/5.2amp peak
Output Voltage	>30kv peak
Oscillator frequency	260Hz
Dwell	2.25 milliseconds
Spark Duration	1.6 millisecond

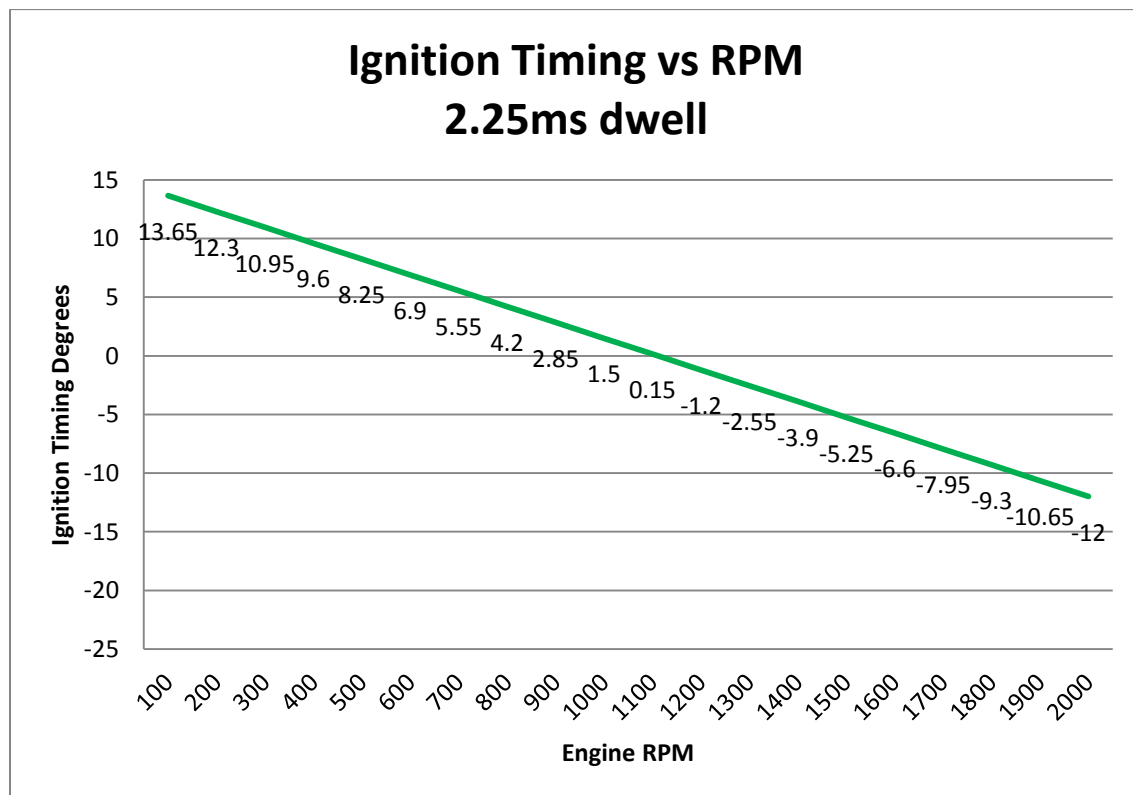

The above chart shows the relationship between ignition timing and RPM with the timer lever in the center or vertical position. At 100 RPM the timing is 13.65° advanced and at 2000 RPM the timing is retarded 12°. This is why the timer lever needs to be pulled back when starting the engine and pushed forward when running at higher RPM.

Replacement coil cross reference numbers are

D514a
C1512
UF414
GM 12573190

Replacement spark plug wire connector part number is

Standard Motor Products ST27
A-BITS coil Term

DX Express Schematic

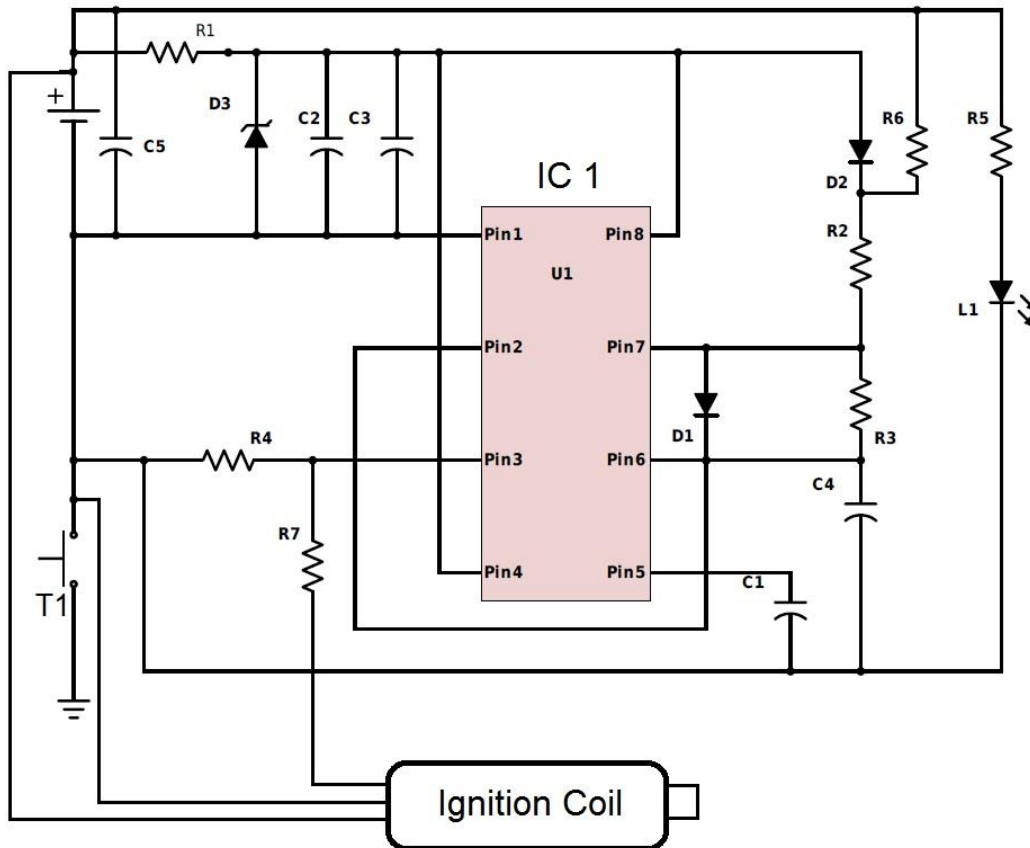

3.0 Glossary of Terms

High Tension

High Voltage, voltage is electric tension measured between two points.

Low Tension

Low Voltage, voltage is electric tension measured between two points.

Dwell Time

Dwell refers to the time the ignition coil is charging.

Negative Ground

A negative ground system has the negative terminal of the battery connected to a common point such as a vehicle chassis to provide the same potential throughout the vehicle.

Positive Ground

A positive ground system has the positive terminal of the battery connected to a common point such as a vehicle chassis to provide the same potential throughout the vehicle. Positive ground potential promotes galvanic corrosion on vehicle body parts and frames and is not commonly used today. The electrical wiring itself is sacrificed however better insulation offers protection and reduces deterioration.

Spark Plug Heat Range

The heat range of a spark plug determines the temperature of the tip of the spark plug while the engine is running. The correct temperature maintains efficiency and keeps the plug clean. The temperature range does not significantly affect electrical characteristics of the plug.

Timer

The timer is a cam actuated mechanical device that provides a signal to a buzz coil.

Points

Points are a cam actuated mechanical switch that provides a signal to an ignition coil.

Condenser

The condenser is a capacitor that connects to ignition points. The function of the condenser is to provide a path for the collapsing magnetic field of the primary side of an ignition coil when the points open.

Average Current

Current measured with respect to time.

Peak Current

Current measured at its maximum value.

Ignition Coil

A device with a pulsing low voltage DC input and a high voltage output.

Ignition Module

The primary function of an automotive ignition module is to interpret incoming cam or crank shaft signals and deliver a pulsed regulated current flow to an ignition coil corresponding to engine position.

Coil Primary Inductance

Inductance measured on the primary or low voltage input side of an ignition coil. Inductance unit of measure is henrys. Typical ignition coil primary inductance ranges between 1-10mh (millihenry).

Primary Resistance

Resistance measured on the primary or low voltage input side of an ignition coil. Resistance is measured in ohms. Typical coil primary resistance ranges between 0.3-6 ohms.

Secondary Resistance

Resistance measured on the secondary or high voltage output side of an ignition coil. Typical coil secondary resistance ranges between 5K-10K ohms.

Coil Turns Ratio

Coil turns ratio refers to the number of winding on an ignition coil primary and secondary. Typical coil ratio is 1:100.

RFI

Radio Frequency Interference or Electromagnetic Interference

Resistor or Suppression Wires

Suppression spark plug wires have internal resistance that reduces the emission of RFI.

Resistor Spark Plug

A spark plug with internal resistance reduces the emission of RFI.

Ignition Timing

Ignition timing on an internal combustion engine determines when an ignition spark is initiated based on the position of mechanical components of the engine.

Ignition Coil Polarity

A typical ignition coil generally can operate polarity in either direction. When the polarity of the primary side of an ignition coil is reversed the output reverses respectively.

Spark Polarity

The polarity on the secondary side of an ignition coil determines the direction of high voltage electron flow. The ideal direction for a spark plug is for the spark to jump from the center electrode to the ground electrode. On a single coil two cylinder ignition system one spark plug always fires in reverse polarity.

Polarity

In a Direct Current circuit electrons flow in one direction from the negative pole to the positive pole. Identifying the poles identifies the polarity. When the poles are reversed the polarity is reversed.

Inductance

The current flowing through a conductor induces a magnetic field around the conductor. The voltage across an inductor is equal to the product of its inductance and the time rate of change of the current through it. Inductance is measured in henry.

Contact Information

Brett Scott
204 S. 5th street
Ethan, SD 57334
(605)227-4693

Email: bscott@santel.net

4.0 Operation & Precautions



Warning High Voltage!

When installing, operating, or servicing the electronic buzz coil use extreme care and recognize the high voltage potential.



Important!

Do not operate the electronic buzz coil without a defined high voltage path! Interrupting the high voltage path poses a health risk and also possible damage to the buzz coil. The High voltage path must be a complete circuit from the coil tower to ground. A failed or disconnected plug wire can cause the spark to arc internal to the coil causing failure.

One year warranty from purchase date.

Purchase Date _____

Rev. 9/15/2017